

PRODUCT INFO

BIKE-PACKER

Rear pannier with lid and QL2.1 system

PFAS free

IP 54

Anti scratch

QL2.1 system

PD620

PS490

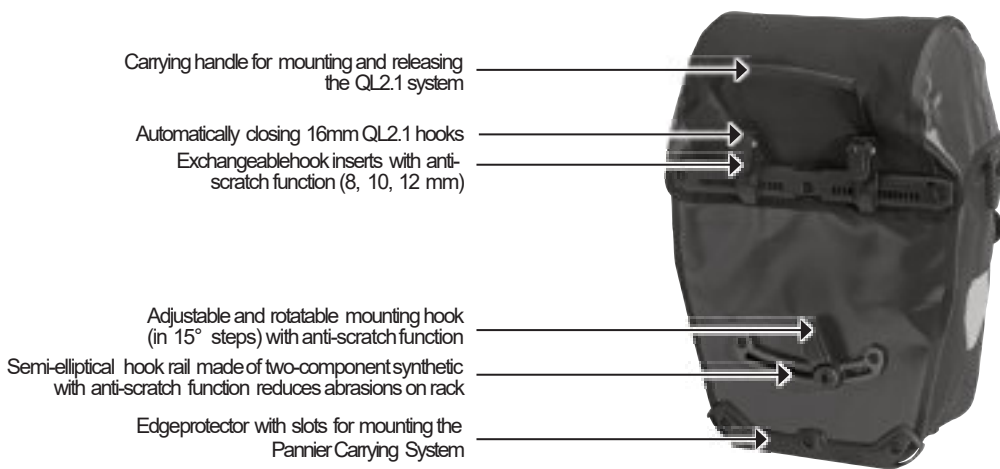
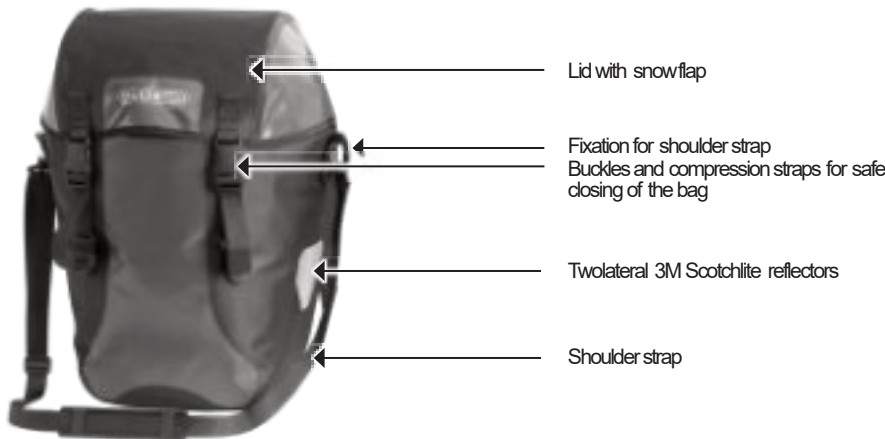

Height cm/in	Width cm/ in	Depth cm/ in	Volume Litres.	Weight grams.	Max. capacity kg.
42/16.5	23/32 9/12.6	17/6.7	20 (pair)	1,040	9

SPECIFICATIONS:

- + Pannier (single) with classic lid closure for large packing volume
- + Bag made of PVC coated polyester fabric
- + QL2.1 mounting system for racks with max. 16 mm tube diameter
- + 18 mm & 20 mm hook available as separate accessory (e.g. for E-bikes)
- + Reduction inserts for tube diameters 8, 10 und 12 mm with anti-scratch function preventing abrasion on the rack
- + Hooks adjustable without requiring tools
- + Lower hook rail made of two-component hard-soft synthetic with anti-scratch function protecting the rack
- + Including integrated inner pocket and shoulder strap
- + Due to its symmetrical form it is possible to use only one bag on left or right side
- + The dust flap - with easily operable pull cord - under the lid provides protection e.g. against water, dust and snow
- + The edge protector prevents contact with spokes and abrasion
- + Highly reflective 3M Scotchlite reflector
- + Easy to clean inside

Contents: Pannier comes with shoulder strap, reduction inserts 8, 10 and 12 mm (1 pair per size)

Optional accessories: Packing Cubes/Pannier Commuting Insert, Pannier Carrying System, Anti-Theft-Device (E125), Outer Pocket 2,1 L, Mesh-Pocket, Bottle-Cage, QL2.1 hook 18mm (E211) & 20mm (E193)

Attention: Maximum load per pannier is 9kg / 20 lbs. We recommend weighing each loaded pannier to confirm that the maximum allowance of the pannier fixation is not exceeded. This practice is advised for both rear and front panniers. CAUTION: The maximum weight capacity of every carrier model is different. Please observe the maximum weight allowance of the carrier fitted to your bicycle. Note: Sometimes the maximum capacity of the panniers fixing system can exceed the maximum capacity of the carrier. DO NOT exceed the maximum capacity of the carrier! Note, that the use of panniers will significantly influence the handling properties of your bicycle.

Attention: As abrasion cannot be ruled out, we recommend that all points where the mounting system contacts the bicycle rack or frame be protected by scratch protection film.

Note: In order to meet standard IP54 (5=protected against dust, 4=protected against splash water coming from all directions) the lid must be properly closed.



QL2.1-SYSTEM

DE MONTAGEANLEITUNG
GB ASSEMBLY INSTRUCTIONS
FR INSTRUCTIONS DE MONTAGE

IT ISTRUZIONI DI MONTAGGIO
NL MONTAGE HANDLEIDING
DK MONTERINGSVEJLEDNING

ES INSTRUCCIONES DE MONTAJE
SE MONTERINGS ANVISNING
NO MONTERINGS ANVISNING

FI ASENNUSOHJEET
PL INSTRUKCJA MONTAZU
JP 装着方法



QL2.1 - MODELS



ACCESSORIES



QL2.1

A

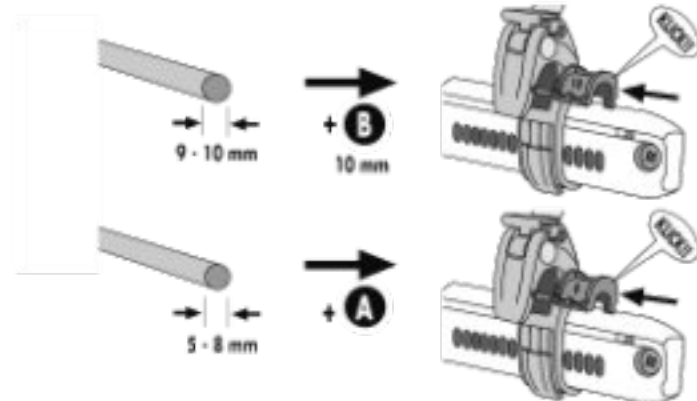
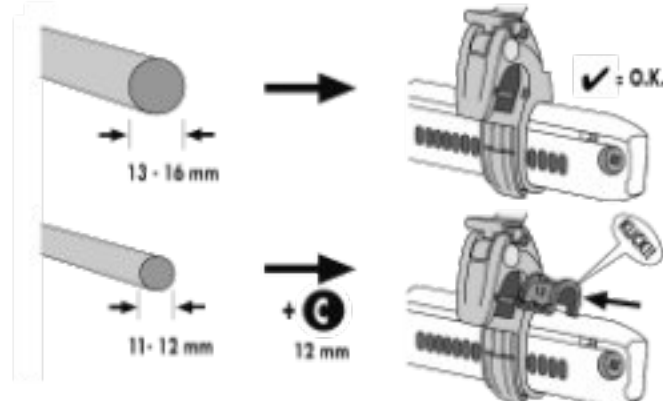
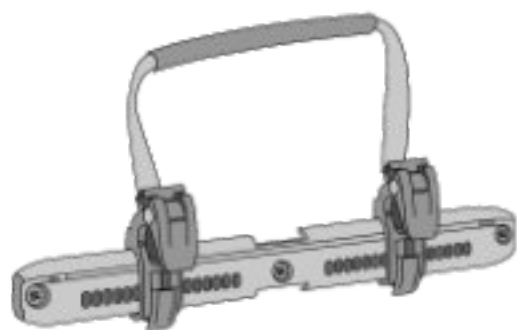

= A 8 mm = B 10 mm = C 12 mm



Anti-Scratch funktion



B

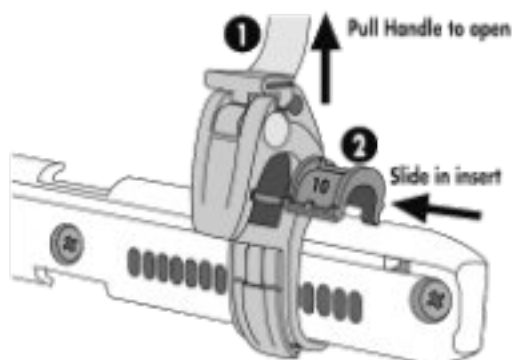

C

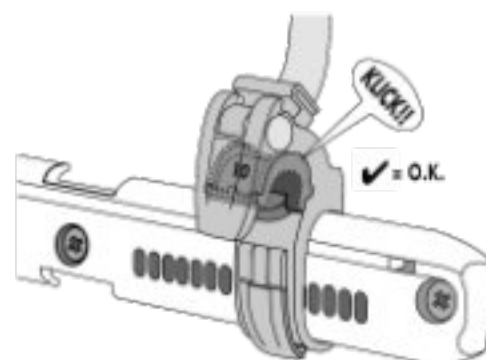

D

