

# PRODUCT INFO

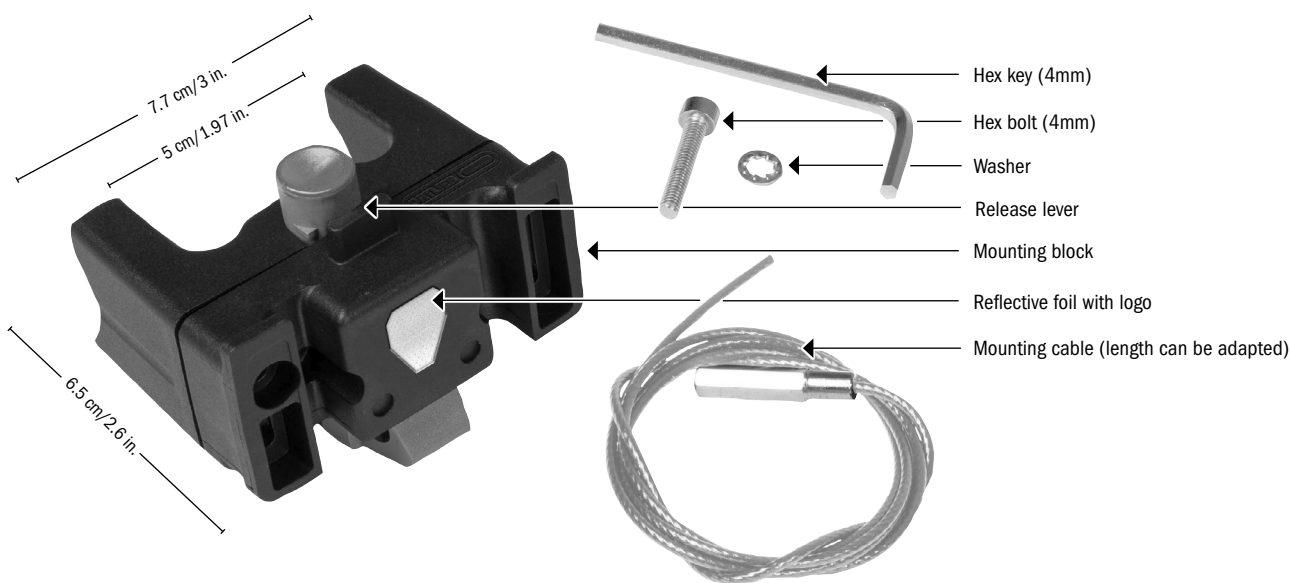

## HANDLEBAR MOUNTING-SET

Mounting system for handlebar bags and baskets - without lock



article code	weight g/oz.	max. load kg/lbs.
E225	125/4.4	5/11

### SPECIFICATIONS:

- + Adapter for mounting ORTLIEB handlebar bags or baskets
- + Simple and fast mounting with only one cable
- + Mounting fits to all handlebars with diameter up to max. 31,8 mm
- + Compatible with the bags and baskets by other brands (e.g. Rixen&Kaul KLICKfix system)
- + A reflective foil on the front of adapter ensures more safety when cycling in the dark without the handlebar bag

**Contents:** Handlebar Mounting-Set (art. code E225) including mounting block, mounting cable with attachment, hex key (4 mm), mounting bolt, washer, mounting instructions

**Optional accessories:** Alternatively we offer the adapter Handlebar Mounting-Set with Lock and 2 keys (art. code E185)

### Attention:

- + Mounting the ORTLIEB Up-Town basket - use the grey mounting cable included with the basket!
- + Maximum load 5 kg/11 lbs.!
- + Do not use with carbon handlebars!

